

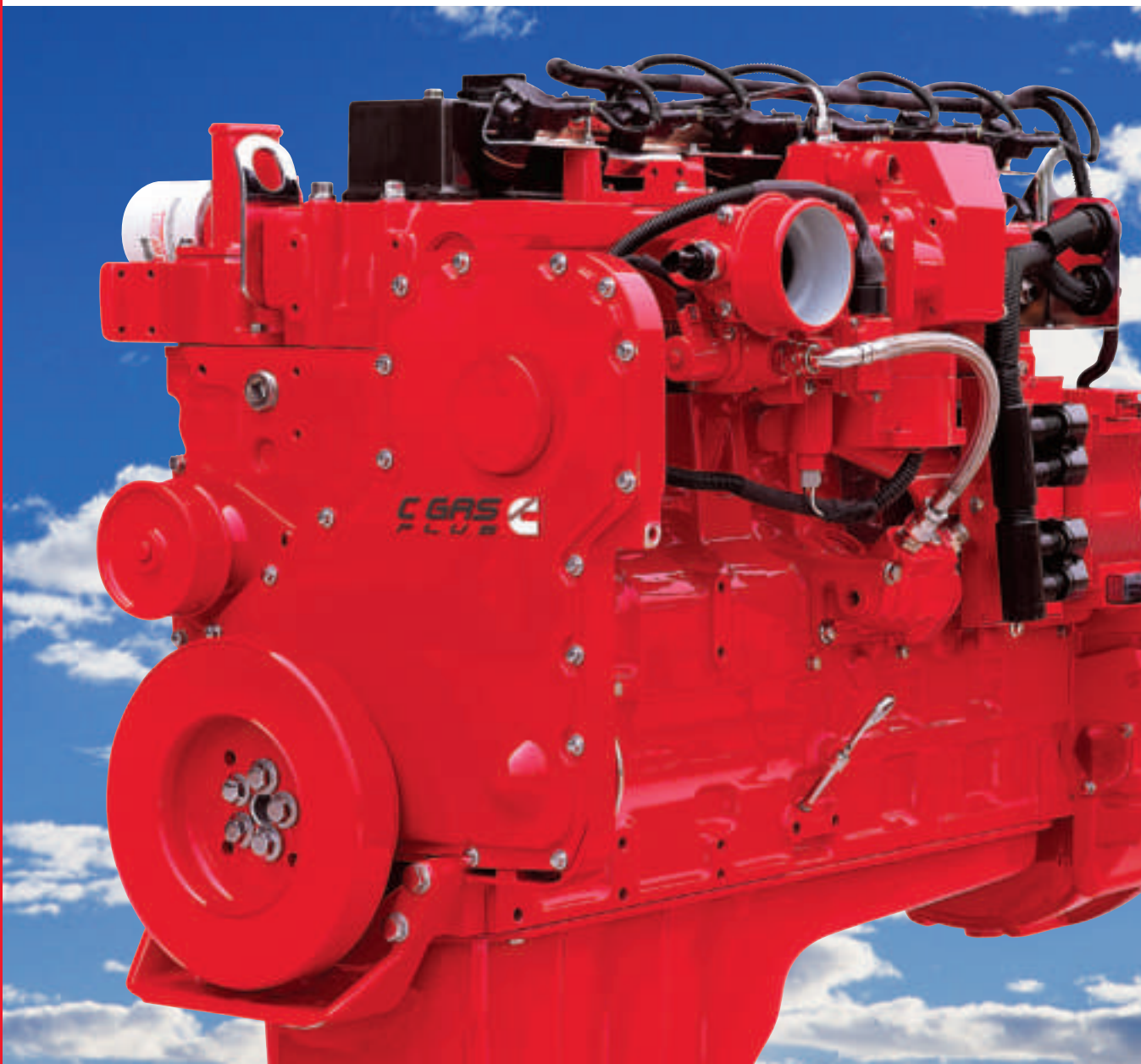

# Every™ Alternative. C Gas Plus.

Natural Gas Engines For Truck And Bus.



# A Clean And Powerful Alternative.

Cummins Westport is a Cummins joint venture company providing 5.9 – 8.9 litre heavy-duty natural gas engines to the global market. Engines are manufactured by Cummins, with aftermarket support provided by the global Cummins distributor and dealer network.

The powerful Cummins Westport 8.3 litre C Gas Plus has the highest power-to-weight ratio in its class and is offered in many of the world's finest buses and trucks.

Building on the rugged, reliable design of Cummins diesel engines, the Cummins Westport C Gas Plus engine is an 8.3 litre, six-cylinder Lean-Burn Spark-Ignited (LBSI) natural gas vehicle engine that delivers from 187 to 209 kW (250-280 hp) with ultra-low emissions. It provides excellent torque, high fuel efficiency and reliable, robust performance, with excellent ratings for both medium-duty and refuse collection truck and urban bus applications. The C Gas Plus is known for easier maintenance and longer service with extreme reliability and durability. Service intervals are similar to the base diesel engine.

Since it was introduced in 2001, more than 5,500 of these clean natural gas engines have powered transit fleets, medium-duty trucks and refuse collection vehicles in cities throughout the world.

The C Gas Plus Electronic Control Module (ECM) allows engine performance to be tailored to fit the vehicle mission with road speed governing and cruise control, as well as an engine protection system and complete self-diagnostics.

## Specifications.

The C Gas Plus combines these performance advantages with ultra-low emissions – certified with a catalyst – to Euro III and IV standards.\* It features lean-burn spark-ignited combustion.

The curves shown represent gross engine performance capabilities obtained and corrected in accordance with Cummins standards. Standard conditions are: 29.36 in. Hg (99.14 kPa) barometric pressure, (500 ft [152 m] altitude, 77°F [25°C] inlet air temperature). Actual performance may vary with different ambient conditions.



## C Gas Plus Ratings

ENGINE MODEL	ADVERTISED KW (HP) @ RPM	PEAK TORQUE N•M (LB-FT) @ RPM	GOVERNED SPEED
<b>TRUCK AND BUS</b>			
CGe 280 30	209 (280) @ 2,400	1152 (850) @ 1,400	2,400 RPM
CGe 250 31	187 (250) @ 2,400	895 (660) @ 1,400	2,400 RPM
<b>TRUCK</b>			
CGe 250 30	187 (250) @ 2,400	1017 (750) @ 1,400	2,400 RPM

## C Gas Plus Specifications

Advertised Horsepower	187-209 KW	250-280 HP
Peak Torque	895-1152 N•M	660-850 LB-FT
Governed Speed	2400 RPM	
Clutch Engagement Torque	556 N•M	410 LB-FT
Number of Cylinders	6	
Bore and Stroke	114 MM X 135 MM	
Engine Displacement	8.3 L	
Compression Ratio	10:1	
Operating Cycles	4	
Oil System Capacity	23.9 L	
Coolant Capacity	10.1 L	
Length	1128 MM	44.4 IN
Width	815 MM	32.1 IN
Height	1222 MM	48.1 IN
Net Weight w/ Standard Accessories, Dry	603 KG	1,330 LB
Emissions	EURO III / IV*	
Fuel Type	CNG/LNG	Methane Number 65 or Greater

For more information, call your local Cummins distributor or Cummins Westport representative, or visit [cumminswestport.com](http://cumminswestport.com).

\*certified at Euro IV for G25 fuel only

## Fuel Capability.

The C Gas Plus is capable of operating on compressed or liquid natural gas (CNG, LNG). With its simple chemical make-up of one molecule of carbon and four molecules of hydrogen (CH<sub>4</sub>), natural gas is a low carbon, clean-burning fuel choice. The C Gas Plus can also operate on up to 100% biomethane – renewable natural gas made from biogas or landfill gas that has been upgraded to pipeline and vehicle fuel quality. Biomethane fuel is carbon dioxide (CO<sub>2</sub>) neutral and using it as fuel reduces vehicle greenhouse gas emissions by up to 90%.

## Features And Benefits.

- **Factory Built, Dedicated Natural Gas Engine** – Built on the same assembly line as Cummins diesels, the C Gas Plus shares many components and parts with the Cummins C Series diesels.
- **Air/Fuel Regulation** – Cummins closed-loop electronic control system is based on Cummins CM556 ECM which maintains efficient operation using sensors to monitor and control various engine parameters, exhaust backpressure, intake manifold temperature, fuel inlet pressure, knock detection, air-fuel ratio and fuel mass flow. Electronically controlled wastegated turbocharger.
- **Air Intake System** – Charge air cooling is utilized to reduce emissions by lowering intake manifold air temperatures.
- **Accessory Belt Drive System** – Self-tensioning serpentine polyvee belt accessory drive system for water pump, engine-mounted fan hub and most alternators. Gear-driven air compressor with provision for gear-driven hydraulic pump.
- **Catalyst** – Required for all models. Engine is certified to Euro III standards.
- **Maintenance-Free Aftertreatment** – The C Gas Plus oxidation catalyst is packaged as a muffler and is maintenance free. No SCR is required.
- **Crankshaft** – Eight counterweight, fully balanced, high-tensile-strength steel forging with induction-hardened fillets and journals for outstanding durability.

- **Cylinder Block** – Full-skirted block increases rigidity and strength. The design provides superior durability, as well as superior piston ring and bearing life.
- **Fuel Tolerance** – Designed for compressed (CNG) or liquefied (LNG) natural gas vehicles. Its wide fuel tolerance – down to methane number 65 – increases uptime worldwide.
- **High-Energy Ignition System** – ECM-controlled for better performance and longer service intervals, improved spark plug and coil durability, plus self-diagnostics. Multiple Spark Discharge (MSD) for smooth idle and spark plug life. Coil-on-plug technology for reliable performance.
- **Oil Filter** – The combination full-flow and bypass Fleetguard® oil filter improves filtration while minimizing oil filter replacement and disposal costs.
- **Pistons** – For extended piston and ring life, a Ni-Resist insert is cast into the aluminum piston and carries the top piston ring.

## Proven “Plus” Technology Maximizes The Equation.

The “Plus” technology of the C Gas Plus features a highly efficient ECM to control its fuel system, engine sensors and high-energy ignition system. Additional “Plus” technology benefits include full drive-by-wire, programmable engine parameters, cruise control, road speed governing, idle speed control and shutdown, accelerator interlock, engine protection system and more. It also features state-of-the-art data links and the ability to interface with Cummins INSITE™ and QuickCheck diagnostic service tools for fast troubleshooting. Life-to-rebuild is the same as a diesel engine.

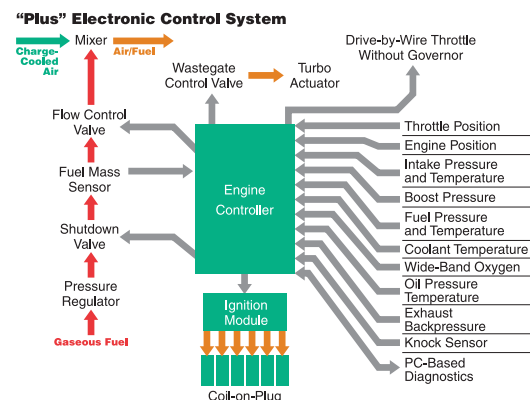

## Cummins Westport – Meeting Every Demand For Power.

Cummins Westport is the industry leader in producing high-quality, economical natural gas engines to meet the global demand for clean power. Cummins Westport engines are the proven reliable power in over 20,000 vehicles worldwide. City fleets worldwide put Cummins Westport C Gas Plus natural gas engines to work – every day.



## Warranty. Every Coverage.

Cummins Westport C Gas Plus bus and truck engines come with standard warranty with full parts and labour on all warrantable failure.\* See your local Cummins distributor or Cummins Westport representative for additional warranty information.

\*Warrantable failures are those due to defects in materials or workmanship.

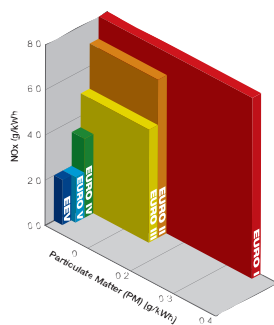

## A Cost Efficient Way To Meet Every Emissions Challenge.

The low carbon content of natural gas leads to lower emissions, and lower fuel costs can lead to lower

total fleet costs. The C Gas Plus met the lowest emissions standards of the day when it was first introduced in 2002. Its reliability, performance and durability set new operating and cost of ownership standards for alternative fuel engines.

To meet the future Euro emission regulations targeting nitrogen oxides (NOx), hydrocarbons (HC), and particulate matter (PM), engine manufacturers will apply advanced technologies including exhaust gas recirculation (EGR), particulate filters and selective catalytic reduction (SCR).

The technology for natural gas engines will not require complex exhaust aftertreatment.

In 2008, Cummins Westport introduced the EURO ISL G to meet Euro V, EEV emission standards with stoichiometric EGR combustion, and maintenance-free three-way catalyst aftertreatment. The ISL G continues the C Gas Plus tradition, with improved fuel economy, performance, and durability.

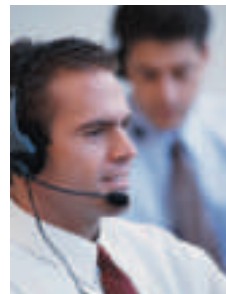

## Customer Support. Every Place You Need It.

The total solution Cummins Westport has created combines fuel availability, government programs and funding, plus additional resources to make natural gas power a viable

alternative. Local service, as well as parts availability for Cummins Westport products, is available worldwide through Cummins global network of 550 company-owned and independent distributor facilities with more than 5,500 parts and service locations in 160 countries. Cummins distributors provide maintenance schedules, warranty information and product-training support worldwide.

**Contact the Customer Assistance Centre –** Cummins specialists provide technical assistance, service locator and product literature 24 hours/day, 365 days/year.

Europe: (44) 1327 886464

Australia/New Zealand: 1-800-351-004

Asia: (86) 13601053517

# C Gas Plus Torque And Power Curves.

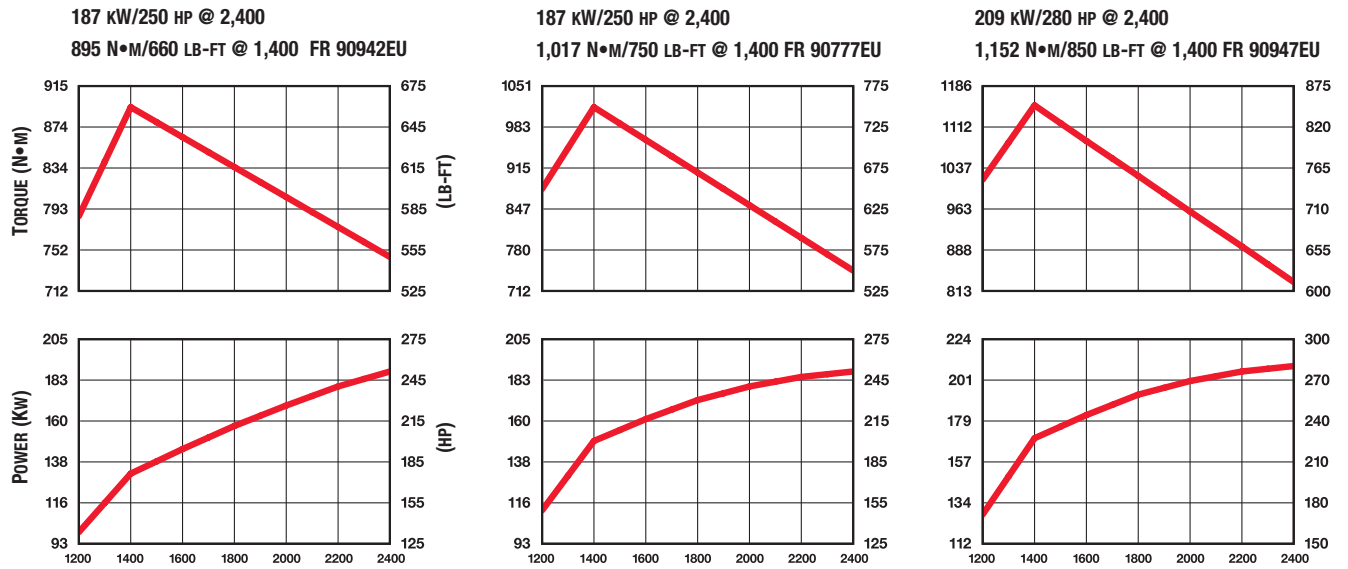

Curves shown represent gross engine performance capabilities obtained and corrected in accordance with Cummins standards. Standard conditions are: 29.36 in. Hg (99.14 kPa) barometric pressure, (500 ft [152 m] altitude, 77°F [25°C] inlet air temperature). Actual performance may vary with different ambient conditions.

## Service Intervals

	HOURS	MONTHS <sup>1</sup>
Oil and Filter	500	6
Primary Fuel Filter	500	6
Secondary Fuel Filter	1,000	12
Overhead Adjustment	2,000	24
Spark Plug Change <sup>2</sup>	1,000	24

1. distance calculated with vehicle in service average speed

2. 2,000 hour option available—contact your Cummins distributor for more details

**EXPLORE EVERY ALTERNATIVE.**

For more information, please contact:



**Cummins Westport Inc.**  
**101-1750 West 75th Avenue**  
**Vancouver, B.C.**  
**Canada V6P 6G2**

Phone: 604-718-8100  
Fax: 604-718-2001  
E-Mail: [info@cumminswestport.com](mailto:info@cumminswestport.com)  
Internet: [cumminswestport.com](http://cumminswestport.com)  
[cummins.com](http://cummins.com)

Bulletin 4103878 Printed in U.S.A. Rev. 9/09  
©2009 Cummins Westport Inc.